

Katadyn BeFree™
Water Filtration System™
(Model # 8019946)



KATADYN GROUP

Log on to our website to learn more about our full line of products including Katadyn, Optimus Stoves and Trek'n Eat Foods.

www.katadyn.com
www.optimusstoves.com
www.trekneat.com
www.spectrawatermakers.com

Katadyn Products Inc.
Pfäffikerstrasse 37
8310 Kempththal
Switzerland
Phone: +41 44 839 21 11
customerservice@katadyn.ch

1 INTENDED USE OF THE Katadyn BeFree™

Congratulations on your purchase of the Katadyn BeFree™. When used properly in accordance with the instructions provided in this manual, this product is designed to reduce the levels of bacteria and protozoan cysts commonly found in fresh water sources to make it safer for drinking. It meets the U.S. Environmental Protection Agency's microbiological water purifier standards for reduction of bacteria (99.999% Klebsiella terrigena) and protozoan cysts (99.9% Giardia and Cryptosporidium). It is ideal for use hiking, camping in the wilderness or traveling in areas where treated water is unavailable.

Water definitions as used in this manual
Fresh water = Untreated water (Lakes, Rivers, Streams, etc.)
Filtered fresh water = Potable drinking water
Treated water = Treated tap water or chemically disinfected water, or boiled disinfected water

7 PERFORMANCE TIPS

To extend the life of your EZ-Clean Membrane™, always use the best available fresh water source. Avoid still water or water in areas of heavy human or animal use.

Filter Integrity Test
If you suspect that your Katadyn BeFree™ may have been damaged in some way, you can perform this quick and easy integrity test in the field. Squeeze 0.5 liters fresh water through the Katadyn BeFree™. **IMPORTANT:** The integrity test only works with a wet EZ-Clean Membrane™.
1. Squeeze 0.5 liters fresh water through the Katadyn BeFree™.
2. Try to blow air - using your mouth - through the drink nozzle into the Hydrapak® Softflask™.
Hydrapak® Softflask™ cannot blow through filter = fiber ok
<- cannot blow through filter = fiber broken
<- can blow through filter = fiber broken
Stop: DO NOT USE FILTER! Replace EZ-Clean Membrane™.

Maintain your Katadyn BeFree™ to keep it operating properly.
A) If the Katadyn BeFree™ leaks near the cap position the EZ-Clean Membrane™ straight on the thread of the Hydrapak® Softflask™ and tighten it firmly.
B) If the Katadyn BeFree™ is dropped hard, check the hollow fibers visually and perform the filter integrity test to make sure the fibers are ok.
IMPORTANT: Do not touch the hollow fibers with a tool or with your fingers. (See WARNING section)

7 PERFORMANCE TIPS (CONTINUED)

C) If water flow is slow, or the Hydrapak® Softflask™ becomes harder to squeeze, use ONE of the EZ Clean steps (Shake, Swish) printed on the outside of the Hydrapak® Softflask™.



Shake
Fill the Hydrapak® Softflask™ with fresh water & shake to easily clean the EZ-Clean Membrane™ in the field
Swish
Remove the EZ-Clean Membrane™ and swish in any fresh water source to clean in the field (Note: DO NOT allow the drink nozzle and top of the filter to contact contaminated water sources).
-OR-
IMPORTANT: Do not rinse the EZ-Clean Membrane™ horizontally under running water. (See WARNING section)

11 PRODUCT REGISTRATION & SPECIFICATIONS

Please take a moment to register your new Katadyn product by completing the short product registration form online at www.katadyn.com. The information you provide will enable us to better serve you with products developed to meet your needs and interests.

Please register your Katadyn product online at www.katadyn.com (**under service section**) and you will be automatically entered into a drawing to win a free Katadyn Group product. We will keep you informed of new products from Katadyn, Optimus and our dehydrated food brands (see our website for more details).

12 PRODUCT SPECIFICATIONS

Flow Rate:	Up to 1L of water per minute
Filter Capacity:	Depends on water quality
Weight:	58 g
Dimensions:	7 x 7 x 23.2 cm

7 PERFORMANCE TIPS (CONTINUED)

If Shake or Swish fail to restore water flow, replace EZ-Clean Membrane™. <- On extended trips, bring along an EZ-Clean Membrane™ Replacement.
D) Trapped air in the EZ-Clean Membrane™ may also reduce flow rates. Fill the Hydrapak® Softflask™ with a small amount of fresh water, close the system and the cap of the drink nozzle, shake the system, open the cap again and squeeze the Hydrapak® Softflask™ until the air goes through the EZ-Clean Membrane™.

8 LONG TERM STORAGE (AFTER YOUR TRIP IS OVER)

Disinfect your Katadyn BeFree™ before storage to prevent microbiological growth within the EZ-Clean Membrane™.
A) Fill a 0.5 liter container with filtered or treated water and add 1 Micropur MP1 Purification tablet or Micropur Forte (MP1 100F). (If not available, use 4 drops of ordinary household bleach.)
B) Pour the solution into the Hydrapak® Softflask™. Close the system by screwing the cap (with EZ-Clean Membrane™) clockwise.
C) Squeeze the entire amount of water through the EZ-Clean Membrane™. D) Allow the components to air dry completely before reassembling the system.
Note: When removing the Katadyn BeFree™ from long term storage, flush the system with 2 liters of filtered or treated water to remove any stale tasting water.

The life span of the EZ-Clean Membrane™ depends on water quality. To extend life of your EZ-Clean Membrane™, clean it regularly. For optimum filter performance replace the EZ-Clean Membrane™ after 1 000 liters or if water flow has slowed or stopped (review Performance Tips to ensure best product performance).
Replacement EZ-Clean Membrane™ Installation
Katadyn BeFree™ Replacement EZ-Clean Membranes™ are available from the dealer where you purchased your Katadyn BeFree™.
To replace your EZ-Clean Membrane™ twist cap in a counter-clockwise motion and remove the EZ-Clean Membrane™ from the Hydrapak® Softflask™. Install new EZ-Clean Membrane™ by screwing it into the Hydrapak® Softflask™ in a clockwise motion.

10 Katadyn BeFree™ LIMITED WARRANTY

2 YEAR LIMITED WARRANTY on Katadyn BeFree™

A) What is covered
Your Katadyn BeFree™ is warranted to be free from defects in materials and workmanship.

B) How long warranty coverage lasts
This warranty lasts two years from the date of purchase of your Katadyn BeFree™.

C) What Katadyn will do
In the event of a defect in material or workmanship within the two-year warranty period, Katadyn will either repair or replace the purchase price of your Katadyn BeFree™, at Katadyn's sole discretion.

D) What is not covered
This warranty does not cover any damage caused by product misuse, abuse or failure to follow instructions provided herein for proper use, maintenance, cleaning or storage. This warranty also does not cover, and expressly excludes coverage for, any incidental or consequential damages arising out of the purchase, use or performance of the product. Some state laws do not allow exclusion or limitation of incidental or consequential damages, so the above exclusion or limitation may not apply to you.

10 Katadyn BeFree™ LIMITED WARRANTY (CONTINUED)

E) How to get service
To receive coverage under this warranty, please return your Katadyn BeFree™ to the retailer where you purchased the product for repair or replacement. If you are not completely satisfied with the service you receive from your retailer, or if you have any questions regarding this warranty, please contact Katadyn Customer Service by telephone, email or in writing at:

Katadyn Products Inc.
Pfäffikerstrasse 37
8310 Kempththal
Switzerland
Phone: +41 44 839 21 11
customerservice@katadyn.ch

F) How state law applies
This warranty gives you specific legal rights. You may also have other rights which vary from state to state.

2 WARNINGS

Using the Katadyn BeFree™ improperly or drinking untreated water can result in exposure to harmful microorganisms and an increased risk of diseases. Reduce your risk of becoming sick by following the warnings and instructions in this manual and by educating yourself on backcountry/travel illness prevention. YOU ARE RESPONSIBLE FOR YOUR OWN SAFETY AND THOSE IN YOUR GROUP. PLEASE USE GOOD JUDGEMENT.

Improper use of the Katadyn BeFree™ or use of a damaged or contaminated EZ-Clean Membrane™ expose you to harmful microorganisms and increase your risk of contracting a gastrointestinal illness. Read this entire manual before assembling or using the Katadyn BeFree™ and follow all instructions carefully. If you have any questions, contact Katadyn at +41 44 839 21 11 or email us at customerservice@katadyn.ch or visit our website at www.katadyn.com

- The Katadyn BeFree™ does not remove viruses.
- Never use the Katadyn BeFree™ to filter seawater or brackish water or chemically contaminated water, such as water from mine tailing ponds or near large agricultural operations. The Katadyn BeFree™ does not make drinkable water from these sources and does not remove chemicals and radioactive materials or particles smaller than 0.1 microns.
- Do not use in freezing conditions (a frozen EZ-Clean Membrane™ could lead to microorganism bypass, resulting in illness)
- Improper threading of cap to the Hydrapak® SoftFlask™ could cause fluid leakage and result in illness.
- Do not hold or squeeze the EZ-Clean Membrane™ with your hand while opening or closing the Katadyn BeFree™ (as showing in the diagram on the next page). Carefully hold the top part of the flask when opening or closing the Katadyn BeFree™, allowing the EZ-Clean Membrane™ to rotate freely inside the flask. Holding or squeezing the EZ-Clean Membrane™ while opening or closing the Katadyn BeFree™ could result in damage or breakage to the filter membrane, thus compromising/damaging the filter (which could allow harmful microorganisms to bypass the filter, leading to illness).

2 WARNINGS (CONTINUED)



Do not hold or squeeze the EZ-Clean Membrane™ with your hand while opening or closing the Katadyn BeFree™



Do not rinse the EZ-Clean Membrane™ horizontally under running water – doing so may destroy the hollow fibers



Do not touch the hollow fibers with a tool or with your fingers.



2 WARNINGS (CONTINUED)

- If the Katadyn BeFree™ has been dropped into a fresh water source, follow instructions for long term storage to completely disinfect filter before use. If the Katadyn BeFree™ is damaged or contaminated, do not use.
- Do not allow fresh water to contaminate the output parts (drink nozzle, filter output).
- To minimize risk, when filtering water, do not splash dirty or fresh water on the drink nozzle and do not share the drink nozzle with others (Note: Illness can be spread by sharing drink nozzle with other people)
- Do not filter any substance or liquid other than fresh water through your Katadyn BeFree™ or the EZ-Clean Membrane™ may become damaged or contaminated.
- Before long term storage, disinfect the EZ-Clean Membrane™ thoroughly to prevent growth of mold, mildew and bacteria which could cause illness (see Long Term Storage)
- Do not use dishwasher or microwave to disinfect the EZ-Clean Membrane™ or the drink nozzle. Doing so will damage or melt the parts from high heat. The Hydrapak® SoftFlask™ can be put in the dishwasher on the top rack.
- Always seek the best fresh water source available.
- Always handle the Katadyn BeFree™ carefully.
- Extend your filter's lifespan by using one of the following EZ Clean options: SHAKE or SWISH every 5 liters (see Performance Tips).
- On extended trips, bring along a Katadyn Replacement EZ-Clean Membrane™.
- READ, UNDERSTAND AND FOLLOW ALL instructions and warnings in this manual before using the Katadyn BeFree™. Failure to follow all warnings and instructions may result in exposure to harmful microorganisms and illness.

3 IMPORTANT SAFETY MESSAGE

Read before using Katadyn BeFree™

When you travel abroad, camp or backpack, you run the risk of illness ranging from the inconvenience and discomfort of diarrhea to more serious illnesses caused by protozoan cysts (i.e., Giardia, Cryptosporidium), viruses and bacteria.

The microorganisms that cause these diseases are often found in the food and water you consume. Lakes, rivers, streams and the local water supply may also be contaminated. To minimize the risk of contracting these illnesses, we suggest that you consult with your physician, state health department or travel clinic 4-6 weeks before you depart.

And while you are traveling, make sure that prepared food is thoroughly cooked according to its specified instructions. Select non-cooked foods (fruits, nuts, etc.) that have intact shells or skins, and always sanitize your hands properly before peeling the food. Wash your hands with soap and warm water thoroughly and often (and use hand sanitizer), especially before you eat or prepare food. Also, in groups encourage everyone to wash their hands frequently. Microorganisms can spread to communal gear from one group member not sanitizing their hands properly. Do not share personal items (i.e. lip balm, eating utensils, toothbrushes, water bottles or bite-valves on hydration bladders). Make sure all food is properly prepared and thoroughly cooked. Filter all drinking water with your Katadyn BeFree™, including water used for brushing teeth, washing your face, etc. according to the instructions in this manual.

If there is any risk of viruses in the water, use an EPA-registered disinfectant such as Katadyn Micropur MP1 Purification Tablets or Micropur Forte (MF 100F), in combination with the Katadyn BeFree™ (Note: Follow all instructions for proper use of Micropur MP1 or Micropur Forte (MF 100F) and wait the appropriate treatment time) or boil your water (must bring to a rolling boil for approx. 1 minute) (Note: The Katadyn BeFree™ does not remove viruses).

4 KEY COMPONENTS IN SYSTEM

- (1) Hydrapak® SoftFlask™
- (2) Drink nozzle
- (3) EZ-Clean Membrane™ (hollow fiber)

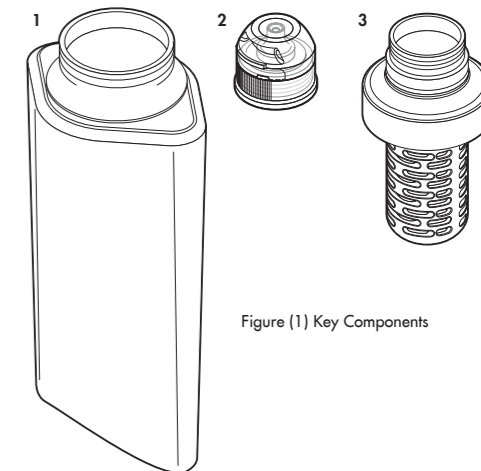

Figure (1) Key Components

5 PRODUCT SETUP

The Katadyn BeFree™ requires minimal setup. For best results, try out the product before first use and familiarize yourself with its operation.

Remove the two tamper evident closures of the drink nozzle (see figure 2):

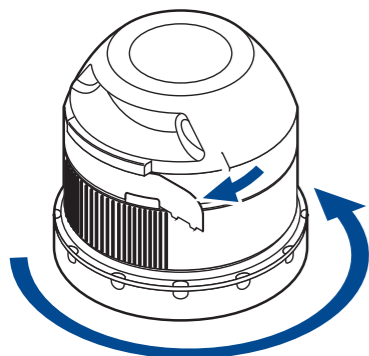

Figure (2) Removing tamper evident closures

Flush system by running approximately 0.5 liters of filtered or treated water through the EZ-Clean Membrane™ (hollow fiber) to remove harmless particles and dust. See following section on Normal Operation on how to filter water.

6 NORMAL OPERATION

A) Open the system by holding the top of the Hydrapak® SoftFlask™ and unscrew the EZ-Clean Membrane™ counter-clockwise (blue ring) (see figure 3).

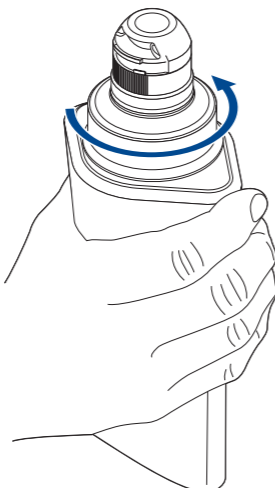

Figure (3) Opening

6 NORMAL OPERATION (CONTINUED)

B) Fill the Hydrapak® SoftFlask™ with fresh water (not salt or brackish water) from the best water source available (such as clear lakes, rivers or streams or faucets or fountains) (see figure 4).

IMPORTANT: Wipe off the fresh water from the outside of the Hydrapak® SoftFlask™ before drinking.

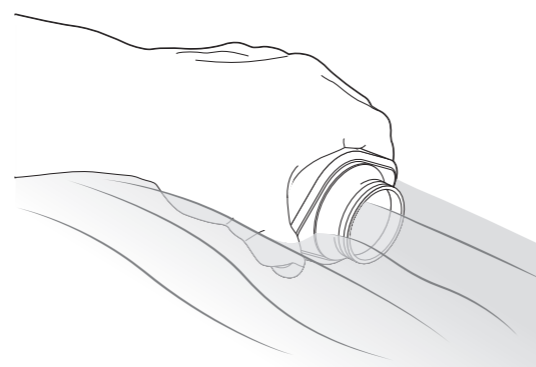

Figure (4) Filling

6 NORMAL OPERATION (CONTINUED)

C) Close the system by screwing filter clockwise onto the Hydrapak® SoftFlask™ ensuring a proper thread seal and avoiding cross-threading which could lead to bypass, ensuring a tight seal (see figure 5)

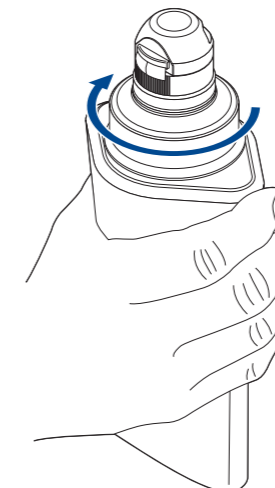

Figure (5) Closing

6 NORMAL OPERATION (CONTINUED)

D) Squeeze the Hydrapak® SoftFlask™ smoothly or drink directly from the drink nozzle (For best performance invert and lightly squeeze the Hydrapak® SoftFlask™ - see figure 6).



Figure (6) Drinking

E) Enjoy the filtered fresh water from your Katadyn BeFree™!